

## Robojo Specifications

### Technology

- MyAppCafé proprietary ordering app
- (2) 32" advertising monitors
- (1) Order queue monitor
- (2) Internal digital menu boards
- (2) POS terminals for onsite ordering
- (2) Barcode/QR code scanners for mobile orders
- Internal maintenance server
- Kawasaki RS005N robot arm

### Refrigeration Equipment

- Temperature safety shutdown
- Milk refrigerator
- Scotsman ice dispenser HID312

### Coffee Equipment

- (2) WMF 5000S+ super automatic
- (2) Bean hoppers in each
- Powder hopper in each
- (12) cup dispensers with 600 cup capacity
- Latte foam art printers
- Internal water filters
- syrup stations with 4 syrup options in each

### Kiosk Details

- Security glass
- Internal video monitoring and troubleshooting system
- (2) Credit card payment devices

### Specifications

#### Electric

- 208V
- 50 Amp 3 phase hardwire

#### Plumbing

- 3/4" incoming water line
- Water pressure 45-87 psi
- Grease trap solution (optional)

#### Drain

- 1.5" drain-line to an indirect floor drain without a pump

### Standard Features

- Capacity: 80 cups per hour avg
- 60 seconds average drink prep time
- 4 drinks produced simultaneously
- 60 minutes per day servicing
- Contactless ordering through mobile app
- Barista quality available 24 X 7
- Out of the box with many payroll deduct & campus cards

### Certifications



# Robojo Specifications

**Front View**

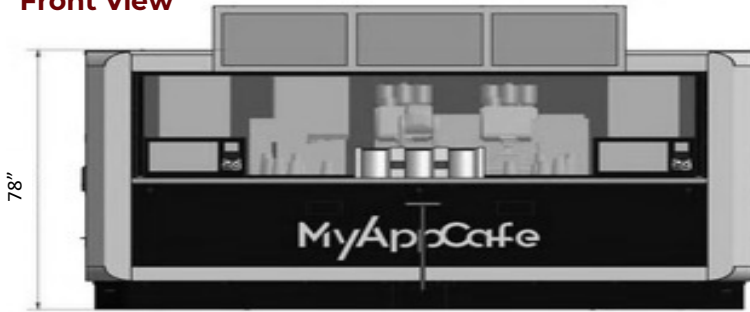

**Top View**

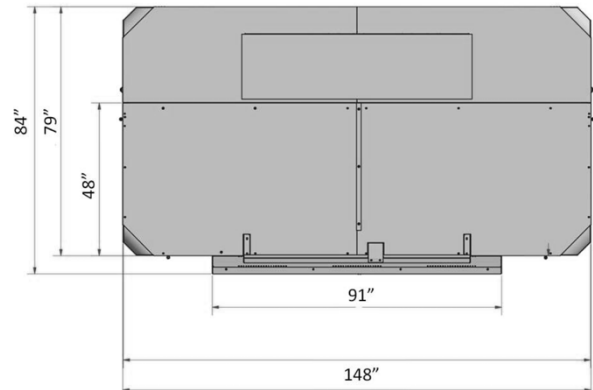

**Side View**

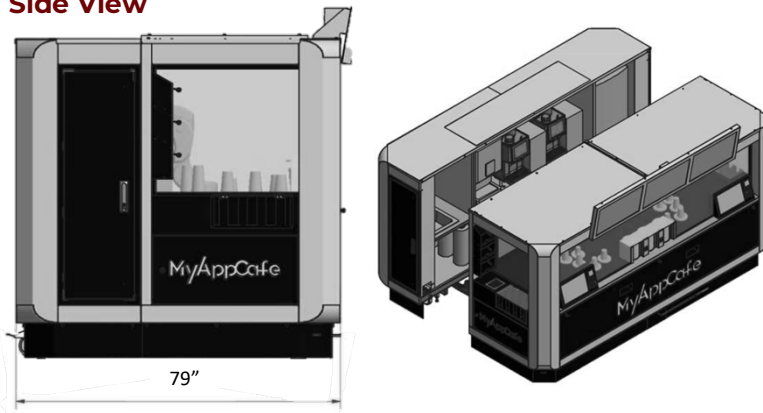

**Top View Servicing**

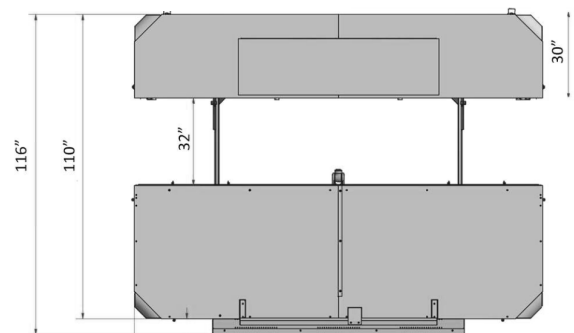

## Utility Connections

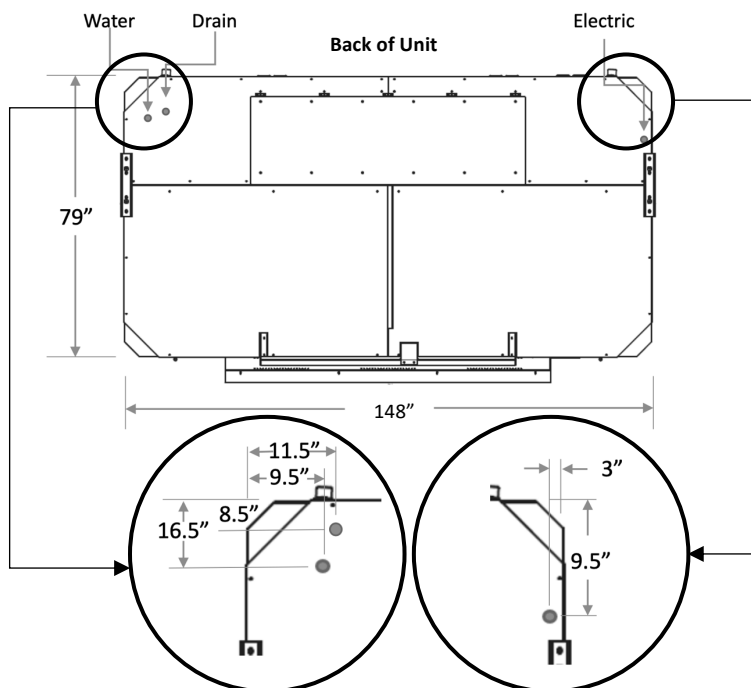

\*Access locations are approximate. Flexible utility connections should be used to accommodate location variation and machine movement.